

CUP

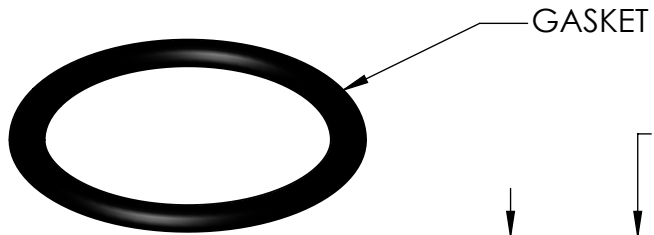

GASKET

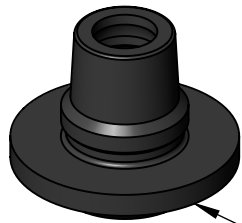

SEAL

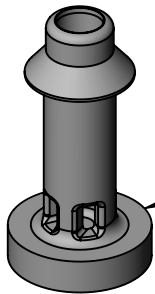

STEM

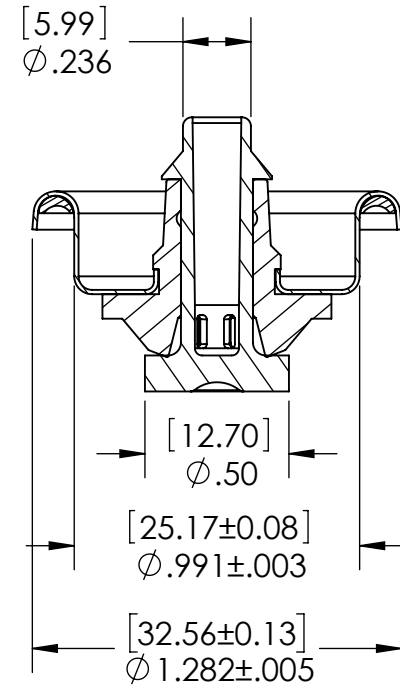
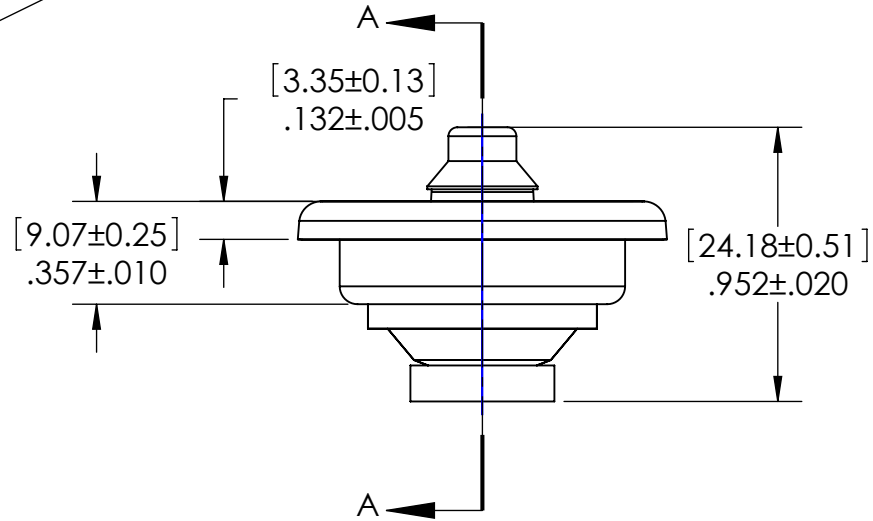

SECTION A-A

PROPRIETARY AND CONFIDENTIAL
 THE INFORMATION CONTAINED IN THIS DRAWING IS THE SOLE PROPERTY OF CLAYTON CORPORATION. ANY REPRODUCTION IN PART OR AS A WHOLE WITHOUT THE WRITTEN PERMISSION OF CLAYTON CORPORATION IS PROHIBITED.



866 HORAN DR.,
 FENTON, MO 63026
 636-349-5333

DRAWN BY:		NAME	DATE	TITLE: 961 Valve	
CHECKED BY:			3/4/09	SIZE A	PART # 1001000961
Tolerances:			DECIMAL INCHES: 0.0 +/- .015" 0.00 +/- .010" 0.000 +/- .005"	MATERIAL:	REV B
ANGULAR: +/- .10 DEG.				SCALE: 3:2	SHEET 1 OF 2



866 Horan Drive
 Fenton, MO 63026 USA
 1-800-729-8220
 1-636-349-5333
 www.claytoncorp.com

SPECIFICATION SHEET
961 VALVE

Valve Part Number: 1001000961

Valve Information:

Parameter	Information
Food Grade	No
Weight†	English: 0.28 oz.; Metric: 7.9 g

Valve Component Information:

Component	Appearance	Material	Other Information
Mounting Cup	Silver	Tin Plate Steel	Top Coating: None Bottom Coating: None
Stem	White	Olefin Polymer	Orifices: English: 4 x 0.080 in. Metric: 4 x 2.03mm
Seal	Black	Neoprene	
Lathe Cut Gasket	Black	Nitrile	

Recommended Crimp Specification (Customer may need to adjust for their specific container):

Measurement	English	Metric
Diameter	1.050 in. — 1.060 in.	26.67mm — 26.92mm
Depth	0.200 in. — 0.210 in.	5.08mm — 5.33mm

Carton Information:

Item	English	Metric
Quantity	2,500	2,500
Size	L: 20 in. x W: 11 in. x H: 14 in.	L: 50.8cm x W: 27.9cm x H: 35.6cm
Weight†	47.1 lbs.	21.4 kg

Pallet Information:

Item	USA	International
Style	USA	USA
Quantity	80,000 / 100,000	60,000
Size	L: 40 in. x W: 48 in. x H: 62 in. / 76 in.	L: 101.6cm x W: 121.9cm x H: 121.9cm
Weight†	1,548 lbs. / 1,924 lbs.	532 kg

Valve Warehouse Storage Information:

Condition	English	Metric
Location	Dry Protected Area	Dry Protected Area
Temperature	40°F — 100°F	4.4°C — 37.8°C
Time	Up to 5 years	Up to 5 years

† Weights are approximates

Approved By: Brennan Fogarty

Date: 11/27/2023