

CUP

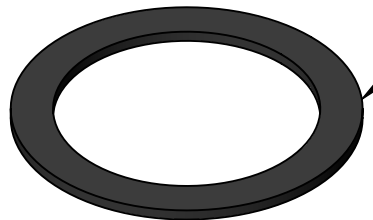

GASKET

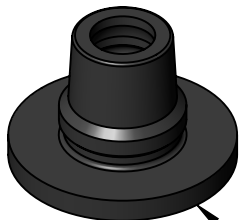

SEAL

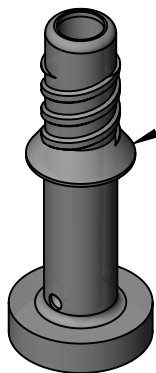

STEM

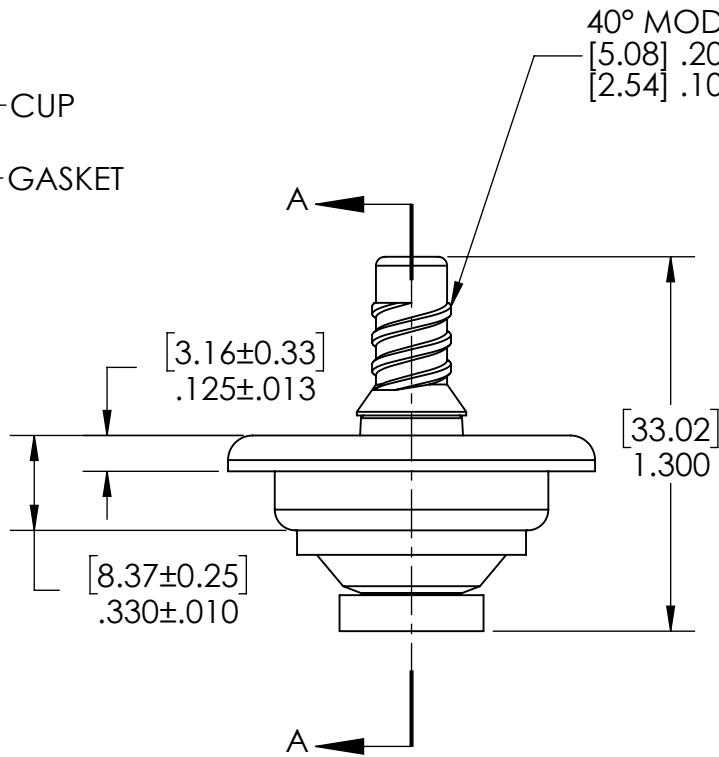

40° MODIFIED ACME THREAD
 [5.08] .200 DOUBLE LEAD
 [2.54] .100 PITCH

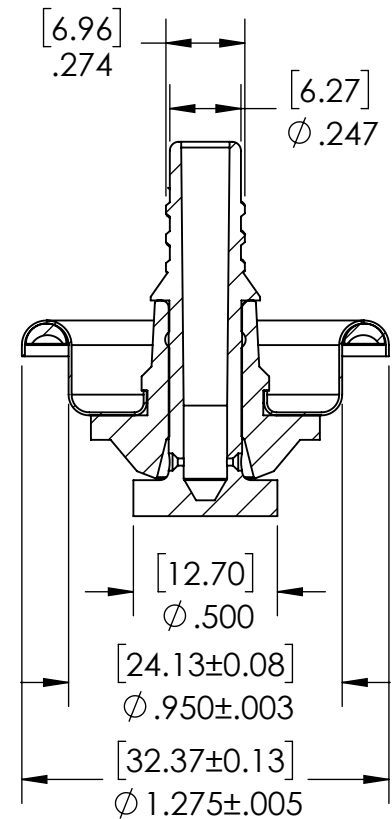

SECTION A-A

PROPRIETARY AND CONFIDENTIAL

THE INFORMATION CONTAINED IN THIS DRAWING IS THE SOLE PROPERTY OF CLAYTON CORPORATION. ANY REPRODUCTION IN PART OR AS A WHOLE WITHOUT THE WRITTEN PERMISSION OF CLAYTON CORPORATION IS PROHIBITED.



866 HORAN DR.,
 FENTON, MO 63026
 636-349-5333

DRAWN BY: Admin		DATE: 07/11/2019	TITLE: 705 Valve	
CHECKED BY:			SIZE: A	REV A
Tolerances:		DECIMAL INCHES: 0.0 +/- .015" 0.00 +/- .010" 0.000 +/- .005"	PART #: 1001000705	
ANGULAR: +/- .10 DEG.			MATERIAL:	SCALE: 3:2
				SHEET 1 OF 2



866 Horan Drive
 Fenton, MO 63026 USA
 1-800-729-8220
 1-636-349-5333
 www.claytoncorp.com

SPECIFICATION SHEET 705 VALVE (DIP TUBE VALVE)

Valve Part Number: 1001000705

Additional Information: This valve works in combination with Clayton Corporation's dip tube assembly.

Valve Information:

Parameter	Information
Food Grade	No
Weight†	English: 0.23 oz.; Metric: 6.6 g

Valve Component Information:

Component	Appearance	Material	Other Information
Mounting Cup	Silver	Tin Plate Steel	Top Coating: Epoxy Lacquer Bottom Coating: Epoxy Lacquer
Stem	Natural- Clear	Olefin Polymer	Orifices: English: 2 x 0.025 in. Metric: 2 x 0.64mm
Seal	Black	Neoprene	
Lathe Cut Gasket	Black	TPE	

Recommended Crimp Specification (Customer may need to adjust for their specific container):

Measurement	English	Metric
Diameter	1.060 in. — 1.070 in.	26.92mm — 27.18mm
Depth‡	0.210 in. — 0.220 in.	5.33mm — 5.59mm

Gassing Information:

Parameter	English	Metric
Valve opening distance if gassing through valve:	0.039 in. — 0.059 in.	1.00mm — 1.50mm

Carton Information:

Item	English	Metric
Quantity	2,500	2,500
Size	L: 19 in. x W: 12 in. x H: 14 in.	L: 48.3cm x W: 30.5cm x H: 35.6cm
Weight†	38.8 lbs.	17.6 kg

Pallet Information:

Item	USA	International
Style	USA	USA
Quantity	80,000 / 100,000	60,000
Size	L: 40 in. x W: 48 in. x H: 62 in. / 76 in.	L: 101.6cm x W: 121.9cm x H: 121.9cm
Weight†	1,282 lbs. / 1,592 lbs.	441 kg

Valve Warehouse Storage Information:

Condition	English	Metric
Location	Dry Protected Area	Dry Protected Area
Temperature	40°F — 100°F	4.4°C — 37.8°C
Time	Up to 5 years	Up to 5 years

† Weights are approximates

‡ Crimp depth may need to be adjusted to obtain a proper seal between the can and valve

Approved By: Brennan Fogarty

Date: 10/5/2021

PART NO.	OVERALL LENGTH	ADAPTER HOLE COUNT	ADAPTER HOLE SIZE (IN.)
1009000150	7.95	0	N/A
1009000155	7.95	4	0.040
1009000157	9.60	1	0.020

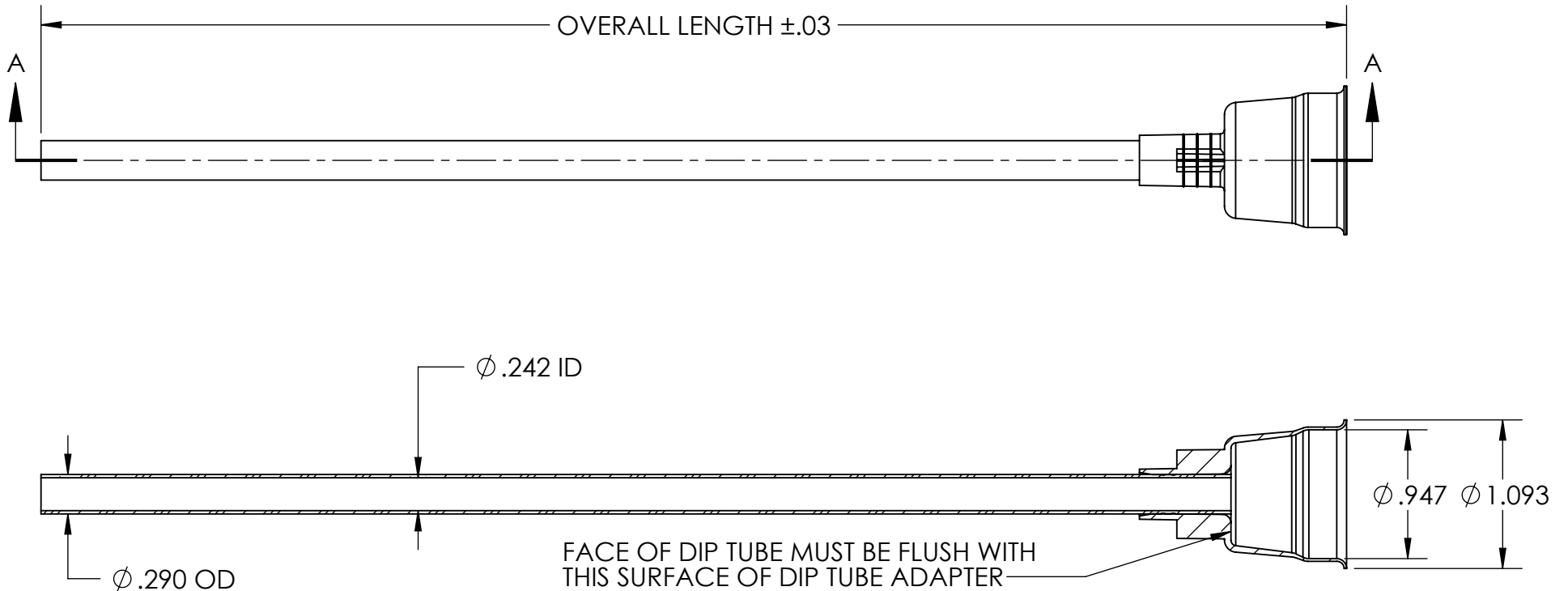

SECTION A-A

DIP TUBE ADAPTER

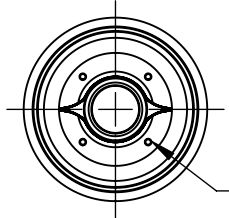

HOLE COUNT & SIZE VARIES DEPENDING ON PART NO.

PROPRIETARY AND CONFIDENTIAL
 THE INFORMATION CONTAINED IN THIS DRAWING IS THE SOLE PROPERTY OF CLAYTON CORPORATION. ANY REPRODUCTION IN PART OR AS A WHOLE WITHOUT THE WRITTEN PERMISSION OF CLAYTON CORPORATION IS PROHIBITED.



866 HORAN DR.,
 FENTON, MO 63026
 636-349-5333

DRAWN BY: BF		DATE: 08/05/2020	TITLE: Dip Tube Assembly	
CHECKED BY:		SIZE: A	PART # 100900015X	REV A
Tolerances: DECIMAL INCHES: 0.0 +/- .015" 0.00 +/- .010" 0.000 +/- .005" ANGULAR: +/- .10 DEG.		MATERIAL: Olefin Polymer	SCALE: 7:8	SHEET 1 OF 2



866 Horan Drive
 Fenton, MO 63026 USA
 1-800-729-8220
 1-636-349-5333
 www.claytoncorp.com

SPECIFICATION SHEET
Dip Tube Assembly

Assembly Part Number: 1009000150, 1009000155, 1009000157

Assembly Information:

Parameter	Information
Food Grade	Yes
Weight†	English: 0.15 oz.; Metric: 4.4 g
Material	Olefin Polymer
Appearance	Natural- Clear

Carton Information:

Item	English	Metric
Quantity	1,200	1,200
Size	L: 23 in. x W: 15 in. x H: 18 in.	L: 58.4cm x W: 38.1cm x H: 45.7cm
Weight†	14.1 lbs.	6.4 kg

Pallet Information:

Item	USA	International
Style	USA	USA
Quantity	24,000	12,000
Size	L: 40 in. x W: 48 in. x H: 78 in.	L: 101.6cm x W: 121.9cm x H: 106.7cm
Weight†	322 lbs.	82 kg

Warehouse Storage Information:

Condition	English	Metric
Location	Dry Protected Area	Dry Protected Area
Temperature	40°F — 100°F	4.4°C — 37.8°C
Time	Up to 5 years	Up to 5 years

† Weights are approximates

Approved By: Brennan Fogarty

Date: 10/5/2021