

CUP

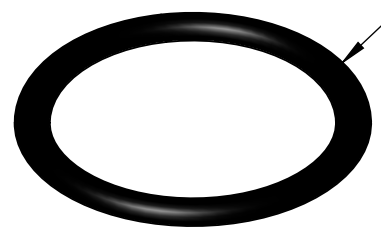

GASKET

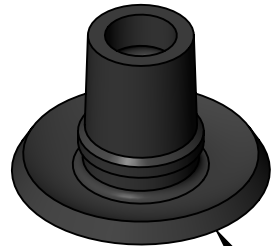

SEAL

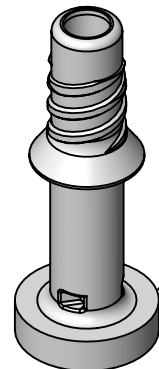

STEM

[3.37±0.33]
.133±.013

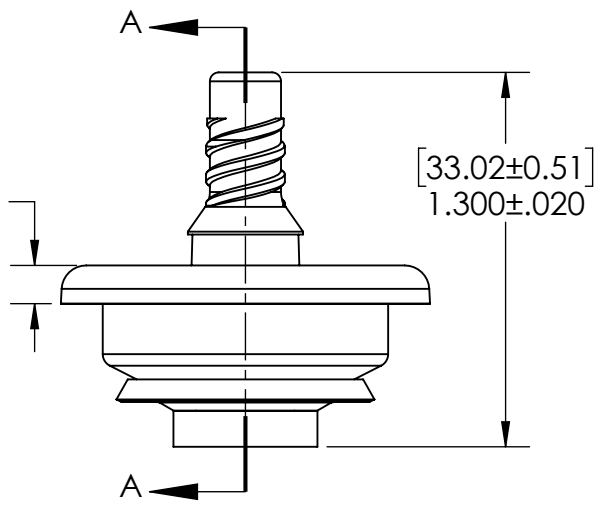

[33.02±0.51]
1.300±.020

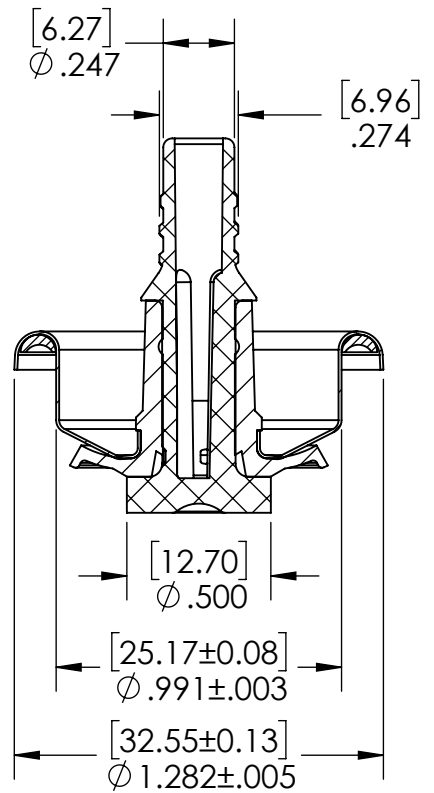

SECTION A-A

PROPRIETARY AND CONFIDENTIAL
THE INFORMATION CONTAINED IN THIS DRAWING IS THE SOLE PROPERTY OF CLAYTON CORPORATION. ANY REPRODUCTION IN PART OR AS A WHOLE WITHOUT THE WRITTEN PERMISSION OF CLAYTON CORPORATION IS PROHIBITED.

CLAYTON CORPORATION 866 HORAN DR., FENTON, MO 63026
636-349-5333

DRAWN BY: KM		DATE: 08/13/2019	TITLE: 4620 VALVE	
CHECKED BY:			SIZE: A	REV B
Tolerances:		DECIMAL INCHES: 0.0 +/- .015" 0.00 +/- .010" 0.000 +/- .005" ANGULAR: +/- .10 DEG.	PART #: 1001004620	MATERIAL:
			SCALE: 3:2	SHEET 1 OF 2



866 Horan Drive
 Fenton, MO 63026 USA
 1-800-729-8220
 1-636-349-5333
 www.claytoncorp.com

SPECIFICATION SHEET
4620 VALVE

Valve Part Number: 1001004620

Valve Information:

Parameter	Information
Food Grade	No
Weight†	English: 0.23 oz.; Metric: 6.5 g

Valve Component Information:

Component	Appearance	Material	Other Information
Mounting Cup	Silver	Tin Plate Steel	Top Coating: None Bottom Coating: None
Stem	White	Olefin Polymer	Orifices: English: 3 x 0.050 in. Metric: 3 x 1.27mm
Seal	Black	Neoprene	
Lathe Cut Gasket	Black	Nitrile	

Recommended Crimp Specification (Customer may need to adjust for their specific container):

Measurement	English	Metric
Diameter	1.065 in. — 1.075 in.	27.05mm — 27.31mm
Depth	0.195 in. — 0.205 in.	4.95mm — 5.21mm

Carton Information:

Item	English	Metric
Quantity	2,500	2,500
Size	L: 19 in. x W: 12 in. x H: 14 in.	L: 48.3cm x W: 30.5cm x H: 35.6cm
Weight†	39.1 lbs.	17.7 kg

Pallet Information:

Item	USA	International
Style	USA	USA
Quantity	80,000 / 100,000	60,000
Size	L: 40 in. x W: 48 in. x H: 62 in. / 76 in.	L: 101.6cm x W: 121.9cm x H: 121.9cm
Weight†	1,292 lbs. / 1,604 lbs.	443 kg

Valve Warehouse Storage Information:

Condition	English	Metric
Location	Dry Protected Area	Dry Protected Area
Temperature	40°F — 100°F	4.4°C — 37.8°C
Time	Up to 5 years	Up to 5 years

† Weights are approximates

Approved By: Brennan Fogarty

Date: 11/27/2023