

CUP

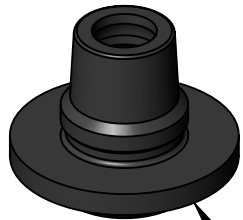

SEAL

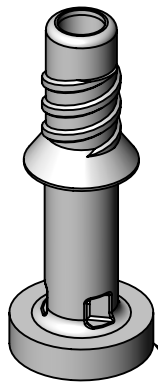

STEM

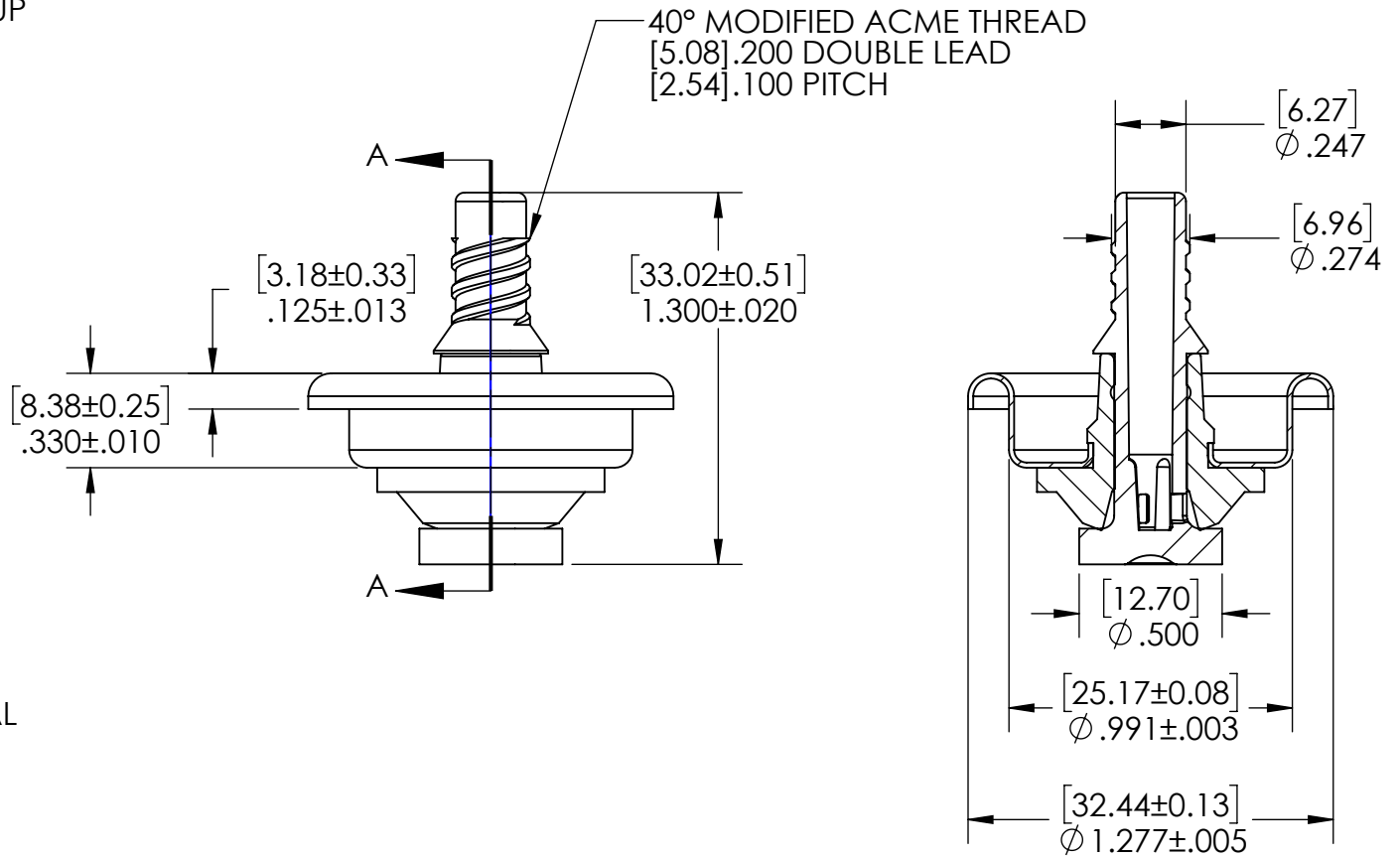

SECTION A-A

PROPRIETARY AND CONFIDENTIAL
 THE INFORMATION CONTAINED IN THIS
 DRAWING IS THE SOLE PROPERTY OF
 CLAYTON CORPORATION. ANY
 REPRODUCTION IN PART OR AS A WHOLE
 WITHOUT THE WRITTEN PERMISSION OF
 CLAYTON CORPORATION IS PROHIBITED.



866 HORAN DR.,
 FENTON, MO 63026
 636-349-5333

DRAWN BY: JPM		DATE: 1/3/13	TITLE: 1941 Valve	
CHECKED BY:			SIZE: A	REV D
Tolerances:		DECIMAL INCHES: 0.0 +/- .015" 0.00 +/- .010" 0.000 +/- .005"	PART #: 1001001941	
ANGULAR: +/- .10 DEG.			MATERIAL:	SCALE: 3:2
				SHEET 1 OF 2



866 Horan Drive
 Fenton, MO 63026 USA
 1-800-729-8220
 1-636-349-5333
 www.claytoncorp.com

**SPECIFICATION SHEET
 1941 VALVE**

Valve Part Number: 1001001941

Valve Information:

Parameter	Information
Food Grade	No
Weight†	English: 0.23 oz.; Metric: 6.6 g

Valve Component Information:

Component	Appearance	Material	Other Information
Mounting Cup	Silver	Tin Free Steel	Top Coating: PET Coating Bottom Coating: PP Laminate
Stem	White	Olefin Polymer	Orifices: English: 3 x 0.070 in. Metric: 3 x 1.78mm
Seal	Black	Neoprene	

Recommended Crimp Specification (Customer may need to adjust for their specific container):

Measurement	English	Metric
Diameter	1.070 in. — 1.080 in.	27.18mm — 27.43mm
Depth	0.185 in. — 0.195 in.	4.70mm — 4.95mm

Carton Information:

Item	English	Metric
Quantity	2,500	2,500
Size	L: 19 in. x W: 12 in. x H: 14 in.	L: 48.3cm x W: 30.5cm x H: 35.6cm
Weight†	39.7 lbs.	18.0 kg

Pallet Information:

Item	USA	International
Style	USA	USA
Quantity	80,000 / 100,000	60,000
Size	L: 40 in. x W: 48 in. x H: 62 in. / 76 in.	L: 101.6cm x W: 121.9cm x H: 121.9cm
Weight†	1,311 lbs. / 1,628 lbs.	451 kg

Valve Warehouse Storage Information:

Condition	English	Metric
Location	Dry Protected Area	Dry Protected Area
Temperature	40°F — 100°F	4.4°C — 37.8°C
Time	Up to 5 years	Up to 5 years

† Weights are approximates

Approved By: Breanna Fogarty

Date: 11/27/2023