

CUP

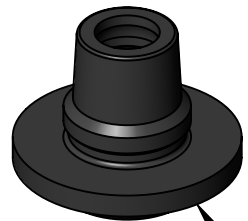

SEAL

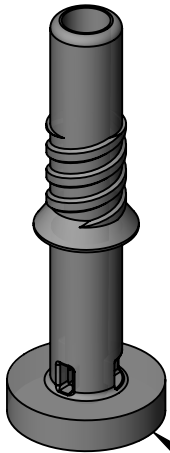

STEM

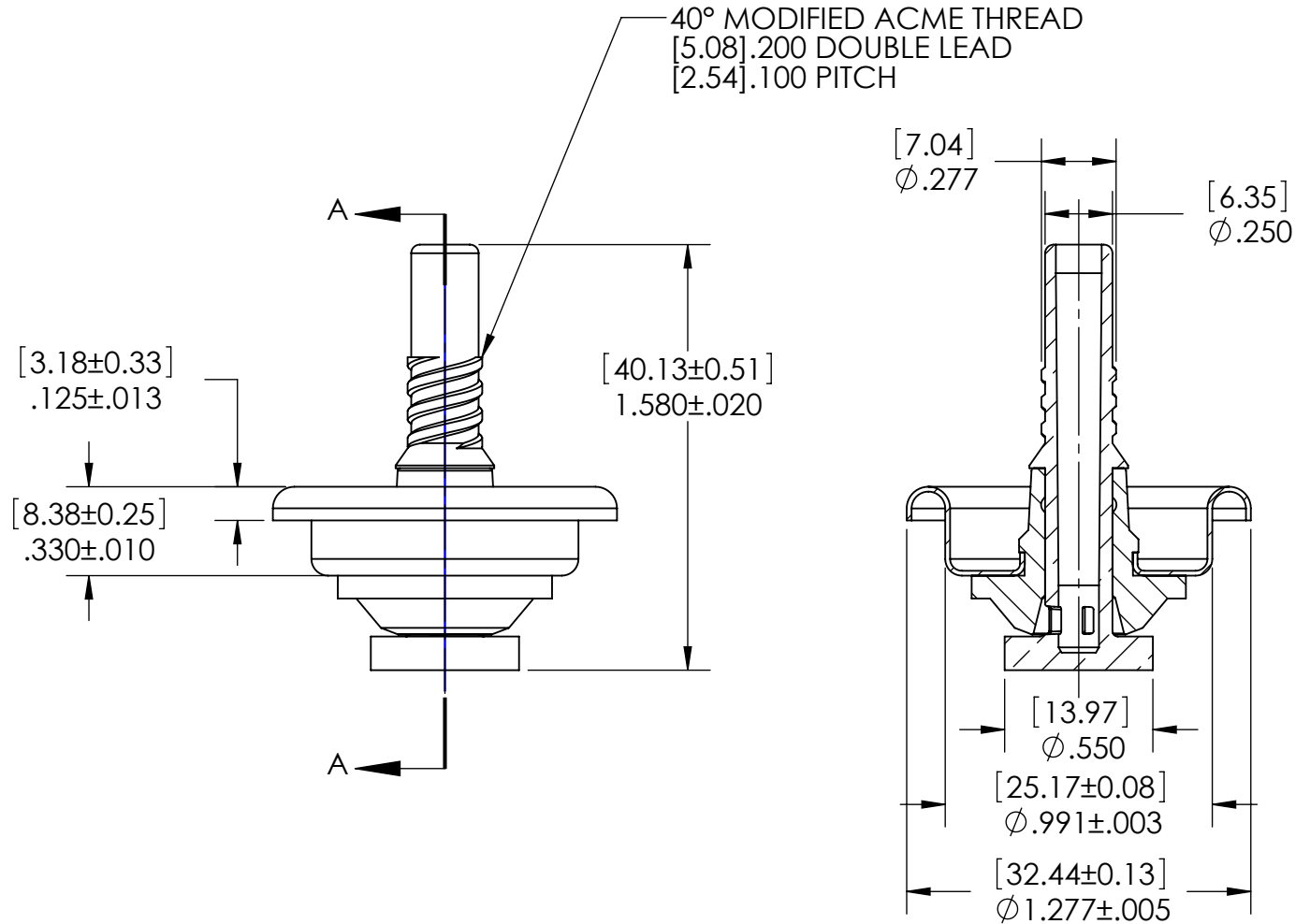

SECTION A-A

PROPRIETARY AND CONFIDENTIAL THE INFORMATION CONTAINED IN THIS DRAWING IS THE SOLE PROPERTY OF CLAYTON CORPORATION. ANY REPRODUCTION IN PART OR AS A WHOLE WITHOUT THE WRITTEN PERMISSION OF CLAYTON CORPORATION IS PROHIBITED.		CLAYTON CORPORATION 866 HORAN DR., FENTON, MO 63026 636-349-5333	
DRAWN BY: DGS		DATE: 3/4/09	TITLE: 1556 Valve
CHECKED BY:		3/18/09	PART # 1001001556
Tolerances: DECIMAL INCHES: 0.0 +/- .015" 0.00 +/- .010" 0.000 +/- .005" ANGULAR: +/- .10 DEG.		SIZE: A	MATERIAL: SCALE: 3:2
			REV C SHEET 1 OF 2



866 Horan Drive
 Fenton, MO 63026 USA
 1-800-729-8220
 1-636-349-5333
 www.claytoncorp.com

SPECIFICATION SHEET
1556 VALVE

Valve Part Number: 1001001556

Valve Information:

Parameter	Information
Food Grade	No
Weight†	English: 0.22 oz.; Metric: 6.1 g

Valve Component Information:

Component	Appearance	Material	Other Information
Mounting Cup	Silver	Tin Free Steel	Top Coating: PET Coating Bottom Coating: PP Laminate
Stem	Natural- Clear	Olefin Polymer	Orifices: English: 3 x 0.080 in. Metric: 3 x 2.03mm
Seal	Black	Nitrile	

Recommended Crimp Specification (Customer may need to adjust for their specific container):

Measurement	English	Metric
Diameter	1.070 in. — 1.080 in.	27.18mm — 27.43mm
Depth	0.185 in. — 0.195 in.	4.70mm — 4.95mm

Gassing Information:

Parameter	English	Metric
Valve opening distance if gassing through valve:	0.039 in. — 0.059 in.	1.00mm — 1.50mm

Carton Information:

Item	English	Metric
Quantity	2,500	2,500
Size	L: 19 in. x W: 12 in. x H: 14 in.	L: 48.3cm x W: 30.5cm x H: 35.6cm
Weight†	37.2 lbs.	16.9 kg

Pallet Information:

Item	USA	International
Style	USA	USA
Quantity	80,000 / 100,000	60,000
Size	L: 40 in. x W: 48 in. x H: 62 in. / 76 in.	L: 101.6cm x W: 121.9cm x H: 121.9cm
Weight†	1,231 lbs. / 1,528 lbs.	424 kg

Valve Warehouse Storage Information:

Condition	English	Metric
Location	Dry Protected Area	Dry Protected Area
Temperature	40°F — 100°F	4.4°C — 37.8°C
Time	Up to 5 years	Up to 5 years

† Weights are approximates

Approved By: Brian Fogarty

Date: 10/5/2021