

SECTION A-A

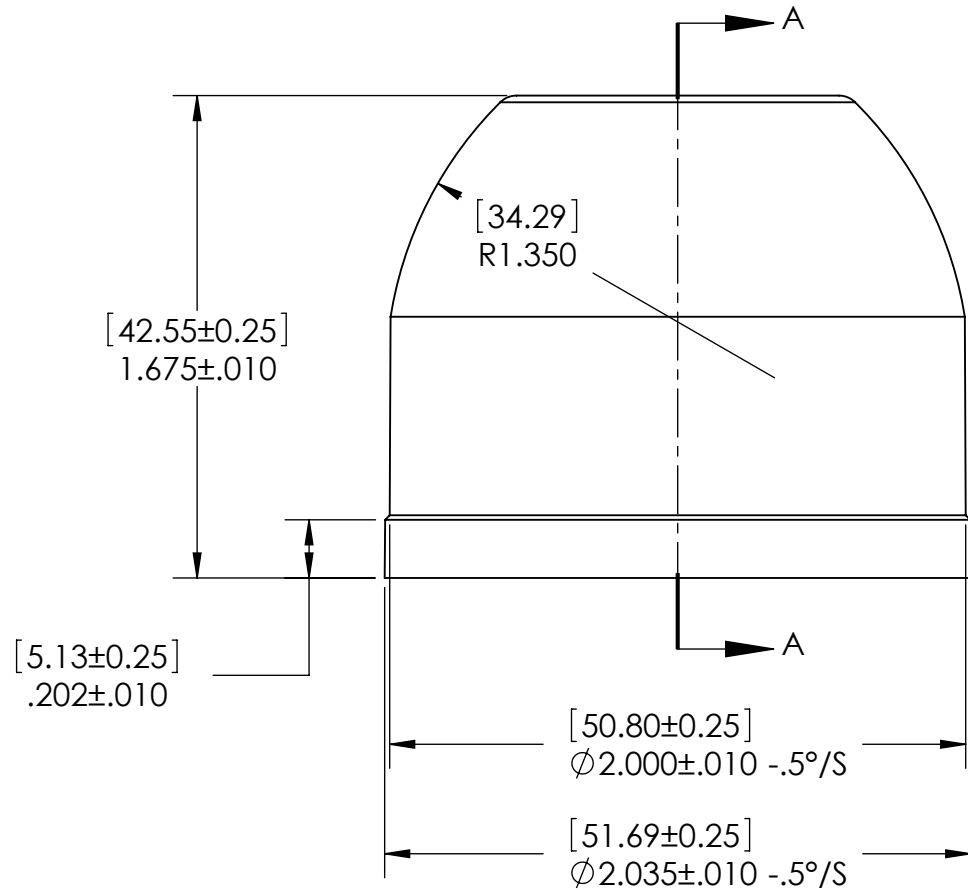

PROPRIETARY AND CONFIDENTIAL
 THE INFORMATION CONTAINED IN THIS
 DRAWING IS THE SOLE PROPERTY OF
 CLAYTON CORPORATION. ANY
 REPRODUCTION IN PART OR AS A WHOLE
 WITHOUT THE WRITTEN PERMISSION OF
 CLAYTON CORPORATION IS PROHIBITED.



866 HORAN DR.,
 FENTON, MO 63026
 636-349-5333

DRAWN BY: DGS		DATE: 10/1/07	TITLE: 53mm Round Top Piston	
CHECKED BY:		7/14/10	SIZE: A	REV E
Tolerances:		DECIMAL INCHES: 0.0 +/- .015" 0.00 +/- .010" 0.000 +/- .005"	PART #: 3003030615	SCALE: 3:2
		ANGULAR: +/- .10 DEG.	MATERIAL: ABS	SHEET 1 OF 2



866 Horan Drive
 Fenton, MO 63026 USA
 1-800-729-8220
 1-636-349-5333
 www.claytoncorp.com

SPECIFICATION SHEET
53mm Round Top Piston

Piston Part Number: 3003030615

Piston Information:

Parameter	Information
Food Grade	Yes
Weight†	English: 0.26 oz.; Metric: 7.3 g
Material	ABS
Appearance	Natural - White

Carton Information:

Item	English	Metric
Quantity	500	500
Size	L: 19.4 in. x W: 8.8 in. x H: 23.0 in.	L: 49.2cm x W: 22.2cm x H: 58.4cm
Weight†	9.6 lbs.	4.4 kg

Pallet Information:

Item	USA	International
Style	USA	USA
Quantity	18,000	18,000
Size	L: 40 in. x W: 48 in. x H: 85 in.	L: 101.6cm x W: 121.9cm x H: 215.3cm
Weight†	386 lbs.	175 kg

Warehouse Storage Information:

Condition	English	Metric
Location	Dry Protected Area	Dry Protected Area
Temperature	40°F — 100°F	4.4°C — 37.8°C
Time	Up to 5 years	Up to 5 years

† Weights are approximates

Approved By: Brennan Fogarty

Date: 9/14/2021