

1.5 X SCALE

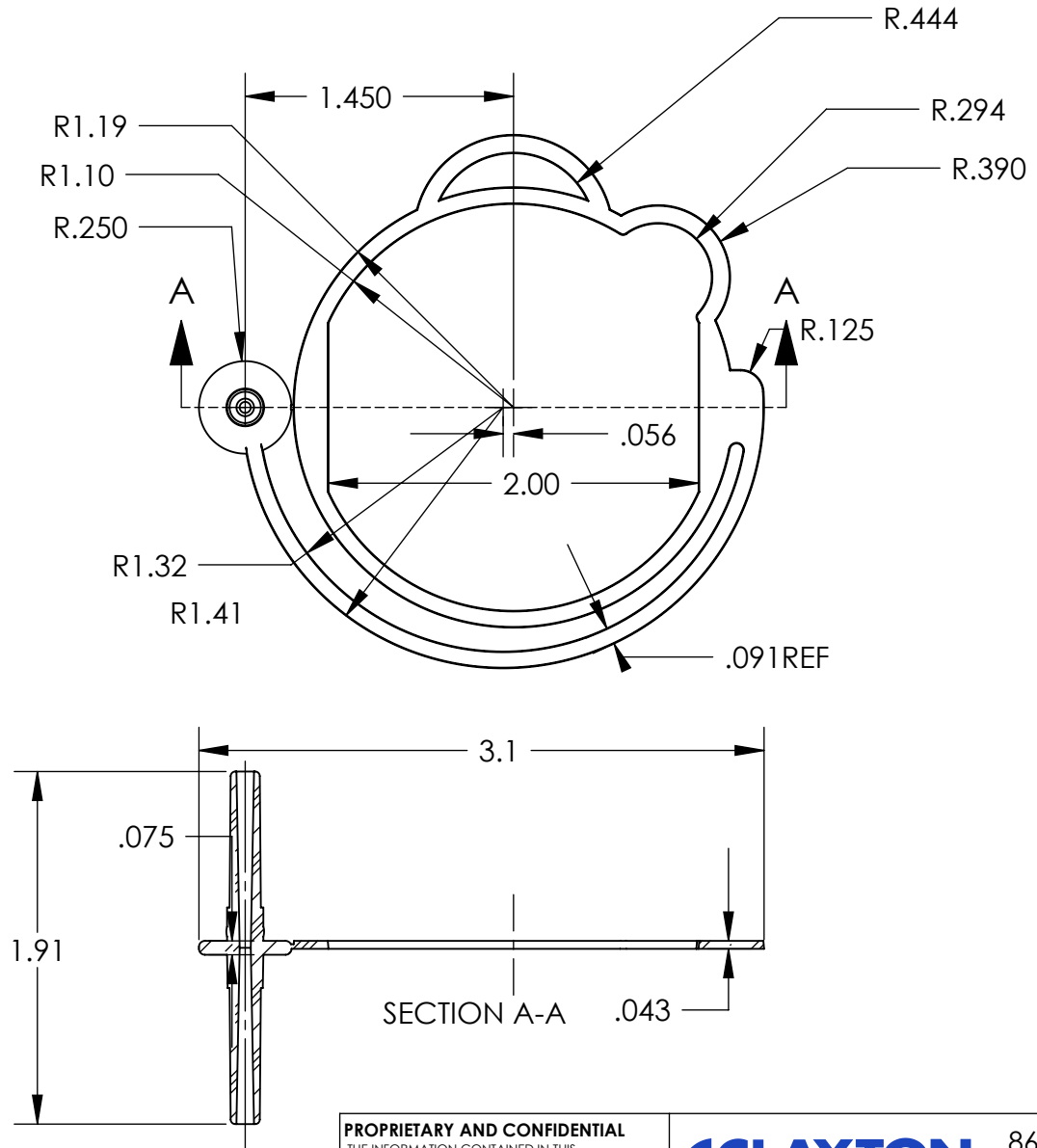

**PROPRIETARY AND CONFIDENTIAL**  
 THE INFORMATION CONTAINED IN THIS DRAWING IS THE SOLE PROPERTY OF CLAYTON CORPORATION. ANY REPRODUCTION IN PART OR AS A WHOLE WITHOUT THE WRITTEN PERMISSION OF CLAYTON CORPORATION IS PROHIBITED.



866 HORAN DR.,  
 FENTON, MO 63026  
 636-349-5333

DRAWN BY: JPM		DATE: 4/12/06	TITLE: Polyclean Nozzle	
CHECKED BY:		-	SIZE: A	REV B
Tolerances:		DECIMAL INCHES: 0.0 +/- .015" 0.00 +/- .010" 0.000 +/- .005" ANGULAR: +/- .10 DEG.	PART #: 3004659885	MATERIAL: Polypropylene Momopolymer -3009001200
			SCALE: 2:1	SHEET 2 OF 3



866 Horan Drive  
Fenton, MO 63026 USA  
1-800-729-8220  
1-636-349-5333  
www.claytoncorp.com

## SPECIFICATION SHEET PolyClean Nozzle

Component Part Number: 3004659885

### Component Information:

Parameter	Information
Food Grade	No
Weight†	English: 0.053 oz.; Metric: 1.49 g
Material	Olefin Polymer
Appearance	Black

### Carton Information:

Item	English	Metric
Quantity	1,000	1,000
Size	L: 19 in. x W: 12 in. x H: 14 in.	L: 48.3cm x W: 30.5cm x H: 35.6cm
Weight†	5.8 lbs.	2.6 kg

### Pallet Information:

Item	USA	International
Size	40in. x 48in.	101.6cm x 121.9cm
Style	USA	USA
Quantity	20,000	15,000
Weight†	156 lbs	57 kg

### Warehouse Storage Information:

Condition	English	Metric
Location	Dry Protected Area	Dry Protected Area
Temperature	40°F – 100°F	4.4°C – 37.8°C
Time	Up to 5 years	Up to 5 years

† Weights are approximates

Approved By: Brennan Fogarty Date: 9/9/20